



3050 FeatherWeight™ Premium Economy Seat

business comfort for the premium or economy cabin

TIMCO
aerosystems



CERTIFICATION OPTIONS

TSO-C127a (16G standard)

Full HIC Compliance to CFR 25.562

Qualification to CFR 121, Amendment 315

Compliant to Special Condition and CRI Requirements

Optional Smoke & Toxicity to ABD00031

Optional Smoke & Toxicity to D6-51377

Certification to EASA and other agency requirements available.

Reduced Cost of Ownership

- Proven light weight structures
- Slim back design to reduce weight and maximize space
- Modular design allowing part interchangeability
- Reduced part count
- Close pitch capability (38" minimum recommended)

Significant weight savings: 59.1 kg (130.3 lbs) per standard double.

includes articulating endbay, bottom cushions, fabric dress covers, tray tables, seat belts and life vest container

Enhanced Passenger Comfort

- Recommended for business and premium economy cabins
- Conforming, flexible back and bottom diaphragms providing "passive" lumbar support
- Ergonomic, rocker-type recline
- Adjustable leg rest (rocker-type control)
- Up to 15" mechanically operated recline
- Up to 75 degree legrest deployment
- Four-way adjustable headrest
- Bolster dress covers

Luxurious details to pamper the business or premium economy traveler.

Innovative Product Design

- Articulating seat bottom pan and legrest assembly
- Patented quick-install front anti-rattle track fittings
- Anodized, high strength baggage bars
- Optimized, handicapped endbay design for easy access
- Heat release "special conditions"-compliant materials
- Customer-designed literature pockets
- Injection-molded end bay bumpers and rub strips
- Quick install front anti-rattle stud

Fewer parts and lighter materials.





3050 FeatherWeight™ Premium Economy Seat

Available Options

- Custom sew patterns for fabric and leather
 - Stitch
 - Bolsters
- In flight entertainment accommodation
 - Top-mounted or retractable DPCU
 - Monitors: up to 10.6" installations
- Flotation cushion
- Center console for video deployment mechanism
- Center console with side-mounted, cradle-style PCU/handset
- Front-mounted PC power units
- Reading light
- Quick install rear track fittings
- Alternative low-profile bottom cushions by all leading suppliers
- Coat hooks
- Tamper-proof life vest box
- Emergency path lighting installation
- Fire-blocking polyurethane foam
- Spring-loaded literature pocket
- Stirrup-style flight attendant step



Flexibility, durability and ease of maintenance.

Line Drawing

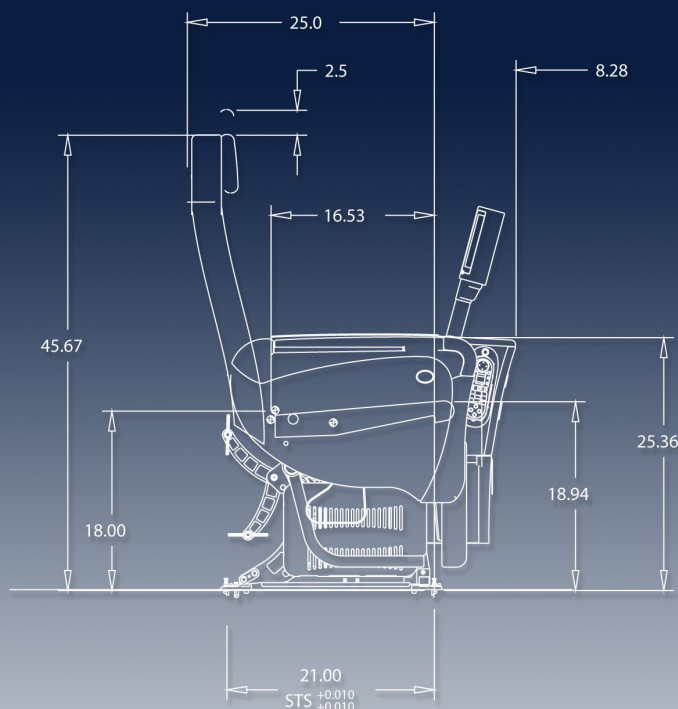

TIMCO
aerosystems